

# NEW! HZ 50

Fully automatic wood chip boiler with **bus compatible microprocessor control**. Perfect combustion through **lambda probe, embers bed sensor and temperature sensor**, optimum heat utilisation by downstream installation of a **multi-way tube heat exchanger** with constantly high operating efficiency and low flue gas temperatures. Rapid and simple installation and a with the **backburn valve** in the drop shaft guaranteeing a high degree of operating safety.



## HZ50

### Dimensions

Boiler height	1480 mm
Flow height	1298 mm
Return height	568 mm
Flue gas pipe connection height	942 mm
Boiler width	754 mm
Overall width	1454 mm
Boiler depth	1205 mm
Power	15-50 kW
Flue gas pipe connection	ø 200 mm
Electrical connection	400 VAC / 50 Hz
Weight	550 kg

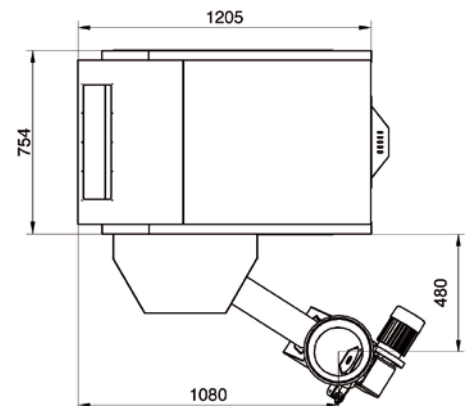
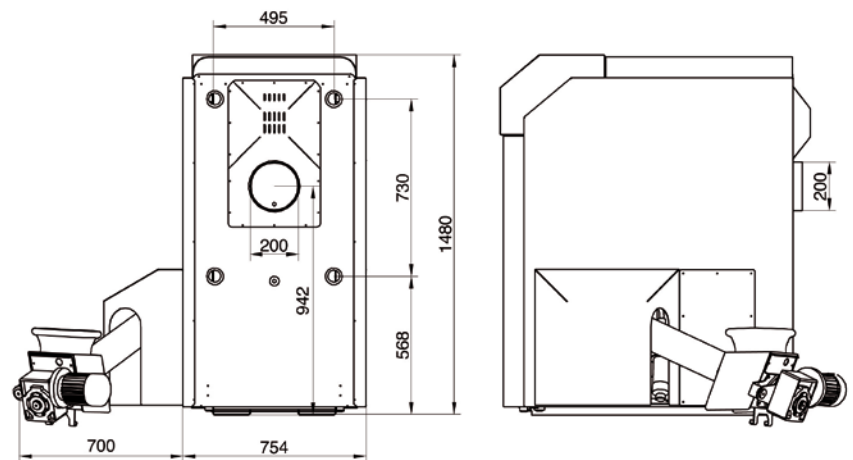

# Biotech

WOOD CHIP HEATING SYSTEM